

SCOPHONY

SCOPHONY'S PART IN TELEVISION

SCOPHONY'S LARGE SCREEN ACHIEVEMENTS

Scophony—practically unknown a few years ago—have set out with the idea that if Home Television is to be one day a universal reality, the pictures must approximate the Home Cinema in size, definition and brightness.

The arduous and patient work of the Scophony engineers and scientists over a period of years has been crowned with success. *The results were demonstrated at Radiolympia 1938, where the Scophony Two-Foot Pictures for the Home were the biggest and brightest to be shown.*

This is an outstanding achievement for a variety of reasons, but from the point of view of the television engineer and experimenter the most amazing fact is that in a world of television research on electronic lines, Scophony stand alone in using entirely optical methods; moreover, by employing these means Scophony have actually set the pace for large screen television developments in general.

Scophony have not limited themselves to Home Television only. By employing optical methods Scophony succeeded also in evolving and demonstrating television Projectors for large pictures six feet by five feet with adequate brightness, which can comfortably be seen by an audience of 500-750 people. These projectors are intended for smaller cinemas, clubs, schools and the like, and work on apparatus capable of providing full size cinema screen television is now in progress.

The fact that the above results have been achieved on lines entirely at variance with those so far generally employed, merits a brief examination of the past tendencies in television and of the factors underlying Scophony's fundamentally different conception of television problems.

MECHANICAL AND ELECTRICAL SCANNING IN THE PAST

In the earlier methods of television proposed in the eighties of the last century a pencil of light focused into an area on the screen equal to that of a picture element was swept over the whole picture field by means of scanners of the Nipkow disc or single mirror-drum type.

These methods did not involve the conception of storage of picture signals and since the amount of light concentrated in this single pencil had to be distributed over the total area of the picture reproduced by the receiver, the efficiency obviously decreased in proportion to the increase in definition.

Some forty years later, however, it was found possible, with the aid of improvements borrowed from rapidly advancing electrical and radio arts (such as the high vacuum valve and the large area neon lamp) to demonstrate low definition television, even by using these early crude methods. This line of development had to be abandoned because of the far more exacting requirements of high definition television.

Meanwhile another development was going on, starting with the invention of the cathode ray tube at the beginning of this century and with the recognition of the possibility of *electronic scanning* for television receivers and transmitters.

It was found, at least at the transmitting end that electrical storage is possible (without auxiliary apparatus as in picture telegraphy or in the intermediate film recording method) with a suitable design of light sensitive layer.

The employment of the principle of electrical storage has made possible the remarkable technical achievements on the transmission side known to-day.

On the reception side, however, it has not yet been found possible to employ a practical form of signal storage in the electronic type of receiver. In spite of the fact that the biggest laboratories in the world have concentrated in recent years on the development of cathode ray tubes for reception purposes, the results achieved in demonstrable commercial apparatus are still a *compromise* between either a small size picture with adequate brightness or a large enough picture with insufficient brilliance.

SCOPHONY OPTICAL SCANNING

Scophony were the first to tackle seriously the possibilities of *optical scanning* for modern television. It has been found that the early difficulties were not inherent in the principle but only in the orthodox components, such as the scanners and the light relays available at the time.

Novel optical principles were evolved in the Scophony laboratories which resulted in simpler and smaller apparatus with a higher optical aperture than before.

In their successful search for large projected pictures Scophony have effected nothing less than a revolution in television reception by the invention of the *Supersonic Light Control* which provides for the first time practical means of storing picture signals and of projecting a series of picture elements simultaneously. This advantage is absent in present day receivers employing electronic scanning (cathode-ray tubes).

Furthermore, the Scophony Supersonic Light Control provides a great deal of elasticity in the choice of external light sources, as with the same low electrical input, it can modulate light from any desired light source, which is an advantage not present in a modulated light source such as the fluorescent screen of a cathode-ray tube.

It is by making use of these advantages that Scophony have been able to develop large screen home and theatre projection receivers giving pictures of considerable brightness and excellent definition and have also opened up new vistas of big screen cinema television.

Scophony have successfully applied some of their optical-scanning principles to television Film Transmitters and in the chapters to follow, the Scophony home receiver and the theatre projector (junior type), as well as the Scophony universal film transmitter and master generator for synchronising signals will be described.

SCOPHONY AND THE FUTURE

The art of television would without doubt have been poorer if Scophony had not made this contribution to its technique.

Television, however, is by no means static. The finest technical brains in the world are still engaged on its problems. Many technical changes are likely to be produced, and Scophony feel that they themselves are still on the fringe of their technical possibilities, and therefore hope to play an effective part in the future developments of television and in its application for entertainment as well as in communications.

SCOPHONY HOME RECEIVER

The Scophony home receiver gives a projected picture 24" x 20" of a very pleasant black and white colour. This picture is nearly five to six times larger in area than the pictures at present obtainable with the bigger direct view cathode ray tube type of receiver and can be satisfactorily seen by a number of people simultaneously.

Two of the fundamental inventions incorporated in the home receiver which result in a far greater light efficiency than has hitherto been possible, are the *Split Focus* and the *Supersonic Light Control*, brief descriptions of which are given below.

THE SPLIT FOCUS

The *Split Focus* is an optical arrangement of cylindrical lenses with their axes crossed, so that a beam of light is focused in two separate planes. An advantage of the split focus is that where optical scanners are employed, they can be of a considerably smaller size than would be essential with ordinary spherical lens systems; or vice versa, with the same size of scanner a considerably greater aperture of the optical system can be usefully employed. For instance, without the split focus, the scanner in the Scophony Home Receiver would have to be at least twelve times larger.

THE SUPERSONIC LIGHT CONTROL

Present day television reception is hampered by the necessary loss of light through "scanning". As is well known, in the normal way the picture is scanned by a single spot, whether it be at the transmitter or the receiver. This spot has to traverse the whole picture in a particular time.

If the scanned area of the picture consists of 405 lines, each containing 540 picture elements, then the whole picture can be considered as made up of approximately 200,000 elements. Consequently we can only obtain one two hundred thousandth of the light obtainable when the whole of the picture is simultaneously illuminated with the same intensity as the single spot, i.e. under conditions where no scanning is employed, as in cinema projectors. This great light deficiency has been overcome by the invention of the Scophony light control.

The Scophony supersonic light control consists of a container, filled with a liquid, at one end of which is a quartz crystal. When the quartz is actuated by a modulated carrier frequency, the mean carrier frequency of which is the same as that of the quartz, supersonic waves are set up at a speed corresponding to the velocity of the sound waves in that particular liquid. The container has on either side of it a lens so that light can be passed through the container in a direction transverse to that of the supersonic waves. By means of scanners and suitable lenses, an image of the illuminated light control itself can be formed on the screen, the width being the width of one line of the picture and the length determined by the length of the light control liquid column. If the modulation is now applied to the quartz crystal nothing will be seen on the screen until the scanner which is between the screen and the light control is rotated at such a speed that it follows the speed of the supersonic waves in the liquid exactly. The modulation stored in the supersonic waves then becomes visible on the screen. A large number of scanning spots can thus be used simultaneously. In apparatus designed for 405 lines part of a whole line of the picture (representing something like 200 elements) is used *simultaneously*. This means a 200-fold increase in light.

1938

TVHistory.TV Library

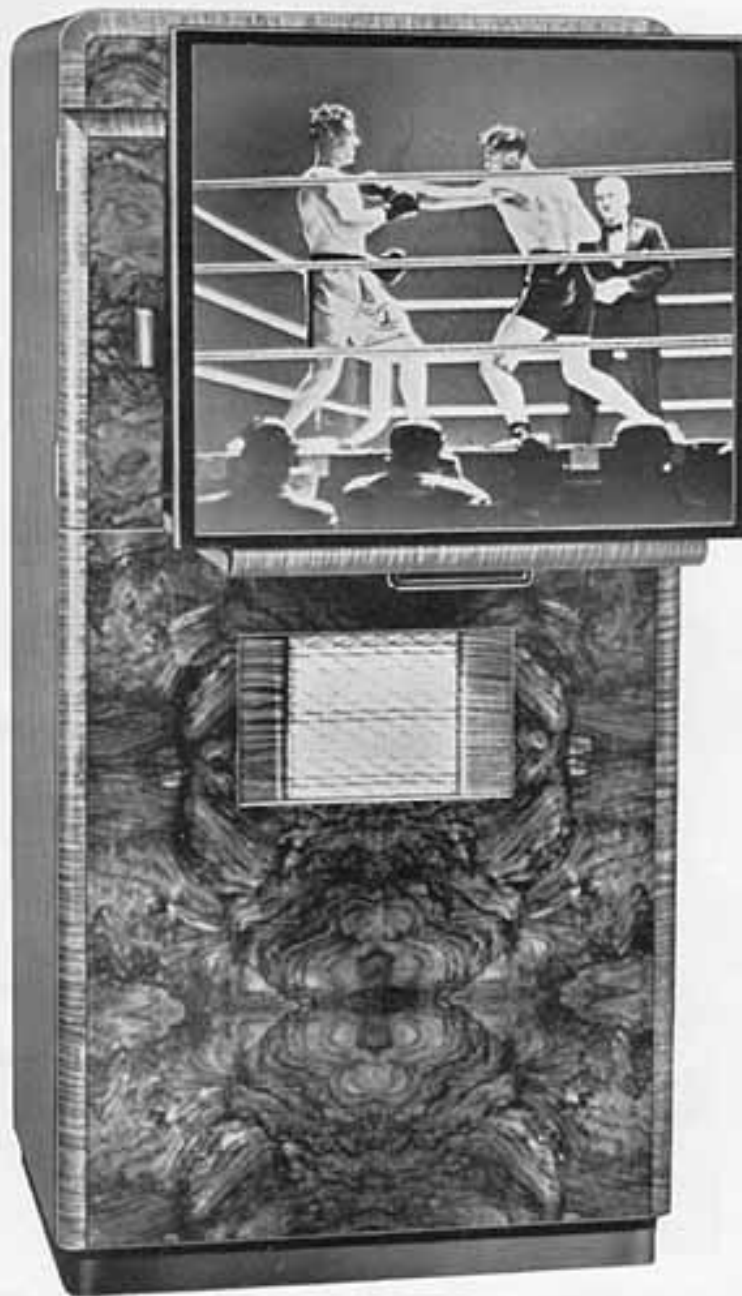

SCOPHONY TWO FOOT SCREEN HOME RECEIVER

1938

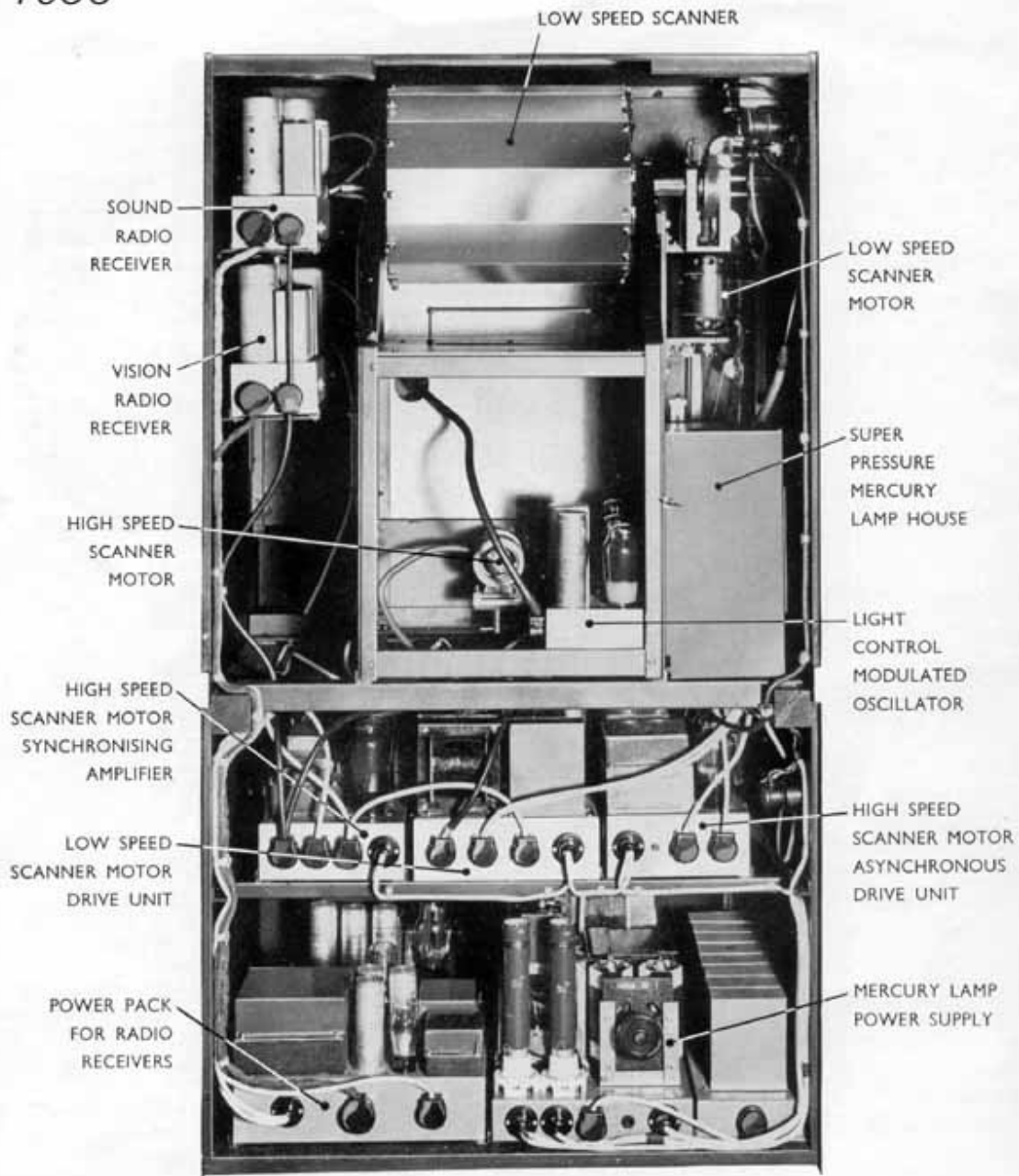

SCOPHONY TWO FOOT SCREEN HOME RECEIVER
WITH BACK REMOVED

1938

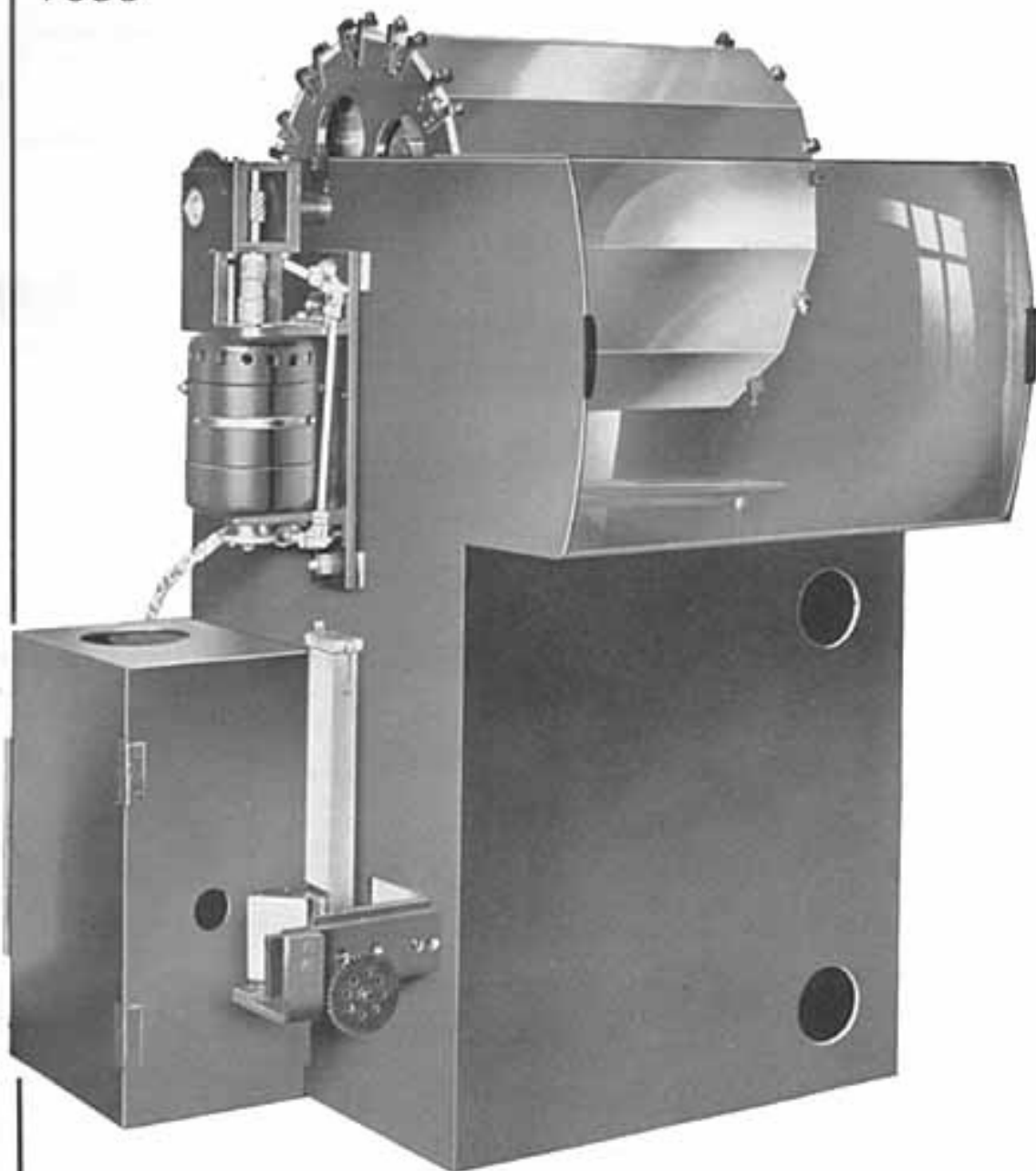

OPTICAL CHASSIS OF SCOPHONY
TWO FOOT SCREEN HOME RECEIVER

The advantage of the light control is also apparent when driving power is taken into consideration. No other known light control could work on high definition television frequencies with reasonable power input, for example a normal Kerr Cell, if at all useful, would require a driving power of a kilowatt compared with 5 to 10 watts required for the Scophony Supersonic Light Control.

THE SCOPHONY SUPER HIGH PRESSURE MERCURY LAMP

The Home 2' screen receiver embodies the *supersonic light control*, the *split focus* and the *super high pressure mercury lamp*, a product of the laboratories of Scophony Electronics Limited. This is the latest development in illumination technique and it is the most efficient and brilliant light source known. For television purposes the Scophony Mercury Lamp is operated from a D.C. source at a voltage of about 80 with a consumption of only $3\frac{1}{2}$ amperes, the total consumption being approximately 300 watts. The brilliancy of this light source is higher than that of a Standard Cinema carbon arc.

The mercury lamp is first focused on to the light control, from the light control to the high speed scanner (a stainless steel polygon), from there on to the low speed scanner which gives the picture-repetition frequency, and through a projection lens on to the 2' screen. Very few optical bodies are used and therefore little light is lost. The diagram shows in skeleton form the Scophony optical mechanical receiver. The operation of the set is extremely simple and there are no expensive parts requiring frequent replacement.

THE RADIO APPARATUS

For the reception of the two transmissions on the ultra-short waves from Alexandra Palace, two separate receivers are used.

THE SOUND RECEIVER

For the sound, 6 valves are employed utilising tuned radio frequency amplification at carrier frequency. This method was adopted in order to avoid constant retuning necessary in a receiver of

the super-heterodyne type, which arises from frequency drift of its oscillator.

Anode bend rectification is employed and is fed to two output valves which work the ten inch loud speaker.

The sound receiver has very high fidelity in order to make full use of the high quality which is transmitted.

THE VISION RECEIVER

Tuned radio frequency amplification is again used with the advantages that a tuning control is dispensed with, operation is simple, and a wide frequency band can be more readily employed. Eight valves are used of which four are R.F. amplifiers and two are diodes for rectification and separation of synchronising impulses.

THE LIGHT CONTROL MODULATOR

The output from the vision radio receiver is via a low impedance output valve and co-axial cable to the light control drive unit, which consists of video amplifier, oscillator R.F. amplifier and D.C. reinsertion valve.

The R.F. amplifier valve is connected to the quartz crystal on the light control and is grid modulated by the video amplifier. The apparatus is so designed that the full 5 megacycles of the two sidebands are fed to the light control.

This is the method at present used, though various alternatives are possible.

THE HIGH SPEED MOTOR

The high speed motor rotates the small mirror polygon which produces the line scanning of the picture. The motor is one which had to be specially developed in the Scophony laboratories. It runs at a synchronous speed of 30,375 r.p.m. Great attention has been given to precision balancing and bearings, and it will run without service for a period approximately equal to the

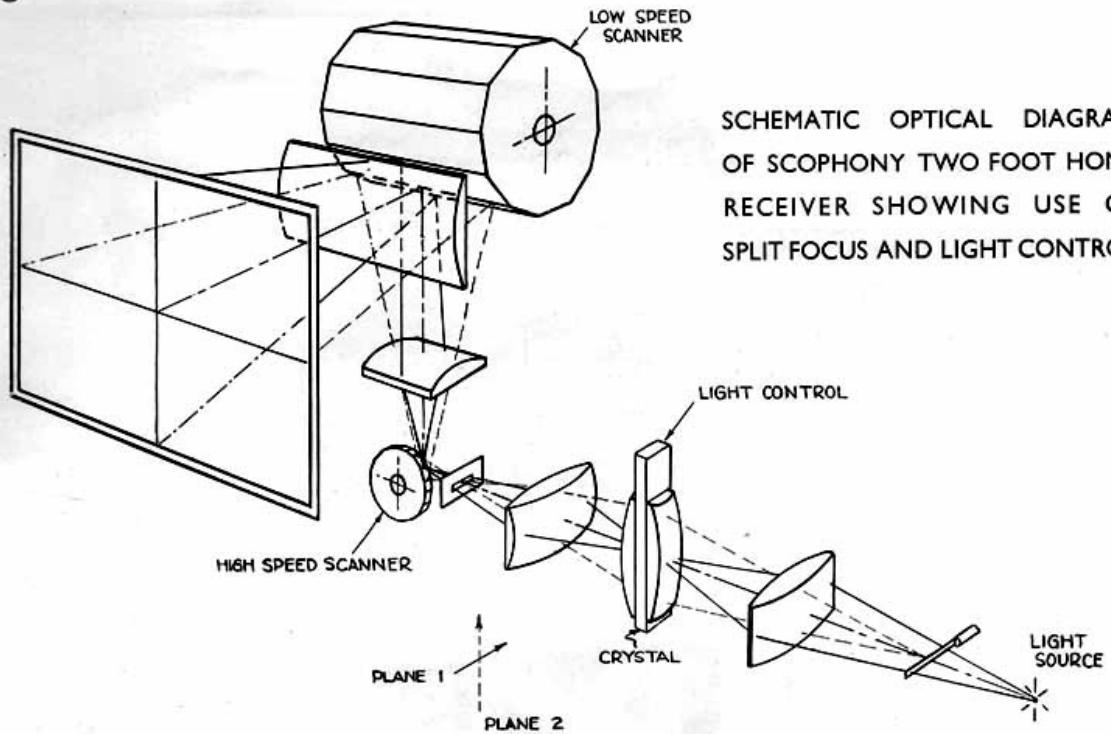

SCHEMATIC OPTICAL DIAGRAM OF SCOPHONY TWO FOOT HOME RECEIVER SHOWING USE OF SPLIT FOCUS AND LIGHT CONTROL

life of a valve used in any radio receiver. With service the life of the motor could be several thousand hours. The motor itself consists of two separate sections built in one case. One section is an asynchronous motor in order to take the motor quickly up to the required speed, and the other a synchronous motor to which are fed the synchronising signals suitably amplified from the vision radio receiver. The motor is very silent in running and cannot be heard outside the cabinet.

THE LOW SPEED SCANNER

The low speed scanner produces the frame scan of the picture and this runs at a relatively low speed. There are 12 mirrors on the scanner and this is driven by means of a synchronous motor running at 1500 r.p.m. through a gear box to a final speed of 250 r.p.m. The alternating current to drive the motor is produced by amplifying the frame synchronising pulse obtained from the vision radio receiver.

GENERAL

The total number of valves at present used in the Scophony large screen home receiver is 39 including all rectifiers, and the mercury lamp power supply.

CONTROLS

The controls are essentially simple. Starting is by means of a delayed push button switch. This switches on all filaments, power supplies and mercury lamp. Switching off is also by push button. Both these are located conveniently at the side of the cabinet.

There is one control for sound volume and one control for vision gain, which controls the contrast. Another control is provided for picture brightness.

On the scanners there is one speed control with synchronising locking switch and one for frame adjustment. A focus control knob is also provided for the purpose of occasional adjustments.

1938

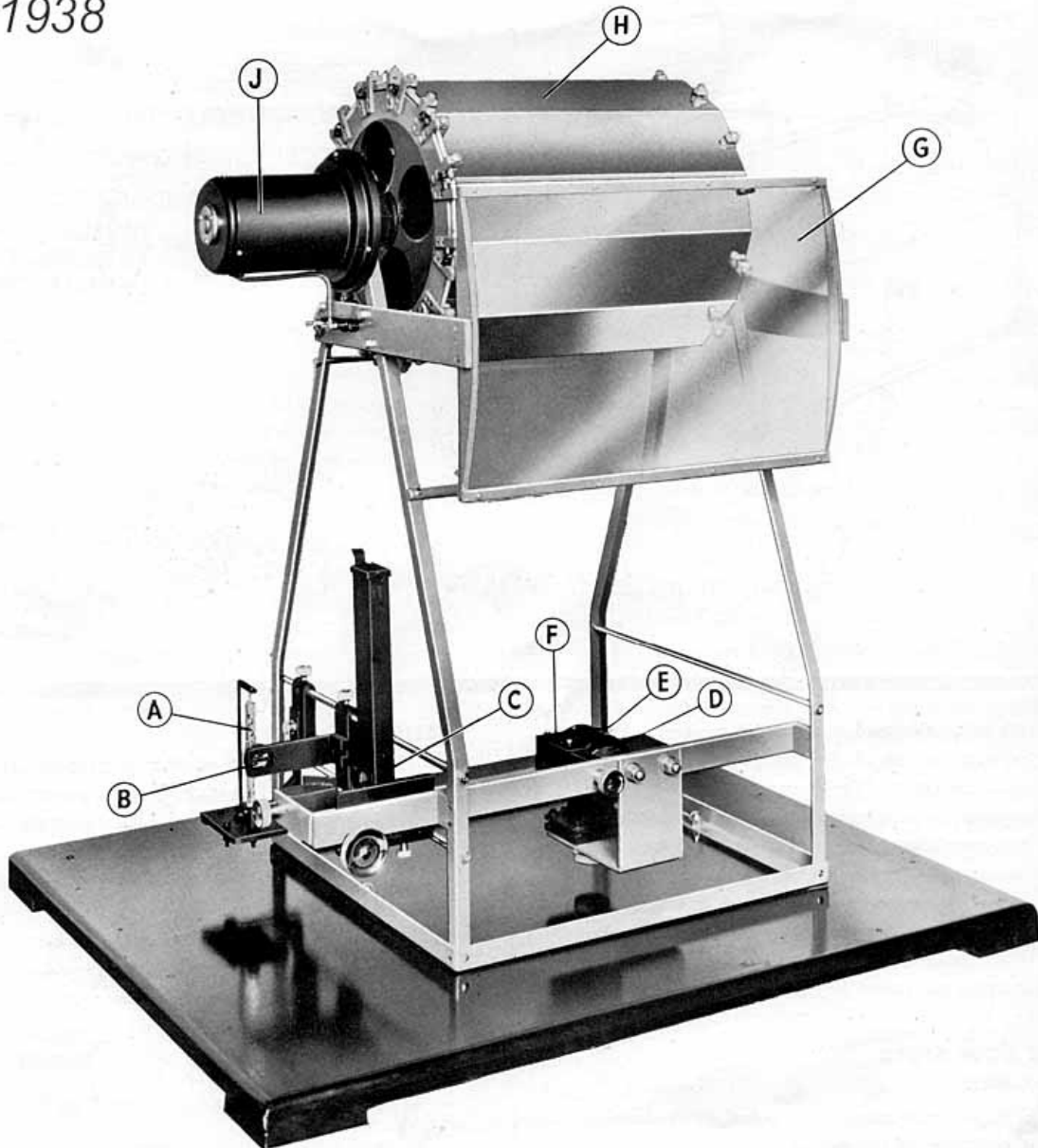

- | | |
|-------------------------------|---|
| A. High pressure mercury lamp | F. Projection lens for horizontal plane |
| B. Optical stop | G. Projection lens for vertical plane |
| C. Light control | H. Slow speed scanner |
| D. High speed scanner | J. Slow speed scanner motor |
| E. High speed scanner motor | |

VISION CHASSIS OF THE SCOPHONY TWO FOOT HOME RECEIVER



STANDARD HIGH SPEED
SCANNER MOTOR

NEW TYPE OF MOTOR
IN COURSE OF
DEVELOPMENT



SCOPHONY THEATRE PROJECTOR (JUNIOR MODEL)

The Theatre Projector type of receiver is based upon the same technical principles as the Home Receiver, and has been specially developed for use in cinemas, clubs, schools, etc. When installed in a suitable hall the picture can be satisfactorily viewed by audiences of 500-750 at a time.

The picture size is 6 ft. by 5 ft. of a black and white colour much the same as that of the ordinary cinema. The screen is flat and the picture is projected from the rear.

Either a standard cinema arc or a super pressure mercury lamp is used as a light source.

The brightness of the screen is sufficient to permit subdued illumination of gangways and passages, as required by the Regulations of Local Authorities.

The electrical gear apart from the light control modulated oscillator is contained on a separate rack.

Two radio receivers are used of the tuned radio frequency type, one for sound and one for vision.

The vision signals are fed into a line amplifier which has gain control and H.F. correction control so that picture quality may be maintained irrespective of length of cable. The sound signals are also fed into another amplifier of sufficient power to operate the powerful loudspeakers required for large halls.

The rest of the panels on the rack are, low speed scanner drive unit, high speed scanner drive and synchronous unit, and power supplies with main switch and fuses.

The voltages do not exceed those used in a small cinema.

The Scophony public hall television projector resembles in appearance a standard cinema film projector, with its separate rack for amplifiers and power supplies.

The apparatus is of a type that can easily be handled by any cinema operator.

It is possible to operate the projector from the control rack placed some distance away by using a suitable cable between the two.

1938



SCOPHONY THEATRE PROJECTOR
(JUNIOR MODEL) GIVING A PICTURE 6 FEET BY 5 FEET

SCOPHONY UNIVERSAL FILM TRANSMITTER

By using the Scophony optical principles, it was possible to construct a successful film transmitter with all the advantages of optical scanning which result in a high light efficiency with full definition, whilst using small and rigid revolving masses.

The mechanical construction of the apparatus is such that its useful life is long, approximately equal to that of a standard film projector; readjustments and replacements are not necessary.

The apparatus is simple to handle and maintain in proper order, no greater skill being required than for the correct handling of a standard film projector. The source of illumination can be an arc lamp or a special high pressure mercury lamp. Owing to the method of scanning used, the wear and tear on the film is very little, under no circumstances can the film ignite, even if it is stationary in the gate.

The accuracy which can be obtained by using the Scophony optical-mechanical principles makes the transmitter suitable for use both for Scophony optical as well as for cathode ray receivers.

OPTICAL SYSTEM

An image of an illuminated aperture is formed on the film by a sphero-cylindrical optical system via two revolving polygons mounted at right angles to each other, one revolving slowly forming the vertical scan in conjunction with the film moving continuously in the opposite direction. This moving spot is picked up by another sphero-cylindrical lens system and reproduced as a stationary image on the cathode of an electron multiplier photo-cell, the variations of intensity

of the spot as it traverses the film giving rise to variations in output of the cell, so transforming every small section of the picture into an electrical impulse.

Sequential scanning is obtained by choosing a line frequency which is an integral multiple of the frame scanning frequency. If the line frequency is an odd multiple of half the frame scan frequency the resultant picture is an interlaced one. The line frequency is governed by the synchronising generator. The frame frequency can be 50 when the slow speed scanner is running and 25 when stationary. Assuming 50 cycle supply frequency, the transmitter can be used for interlaced or sequential scanning with 50 or 25 frames per second.

By using a different gate the transmitter may be adapted to scan the film according to the U.S. standard, i.e., 60 frames from 24 pictures per second.

The source aperture is rectangular and of adjustable dimensions. Thus all types of spurious images (such as "beading") caused by the aperture can be completely eliminated.

Spurious images may arise from the amplitude of vertical scan not being exactly equal to the film pitch. Films in general shrink with age. A continuously variable adjustment is provided to compensate for this.

THE HIGH SPEED SCANNER

The high speed scanner motor is driven by a specially designed valve amplifier from the line frequency supplied in sinusoidal form from the Synchronising Generator. The motor consists

1938



SCOPHONY UNIVERSAL FILM TRANSMITTER.

essentially of a phonic wheel tuned to resonate at line frequency. This is connected direct in the anode circuit of a pair of 60 watt valves in parallel operated in the class C condition. Direct current is also passed through the windings of the phonic wheel so as to prevent reversal of the magnetic flux. A subsidiary motor is mounted on the spindle to run the motor into synchronism.

PERFORMANCE

The spot definition is such that an 800 line picture could easily be obtained by reducing the aperture

and increasing the scanner speed. The focus of the spot is maintained up to the four edges of the gate and the illumination is uniform. In the model designed for the B.B.C. London Television standard, a film containing vertical lines with a spacing corresponding to 600 elements can be resolved perfectly. The quantity of light incident on the photo cell is approximately 0.0005 lumens. The photocell is of a multiplier type yielding approximately 0.01 volts picture current for the amplifier. The amplifier is of conventional design with flat frequency response from 0 to 2.5 M.C., but can be made to suit special requirements.

1938

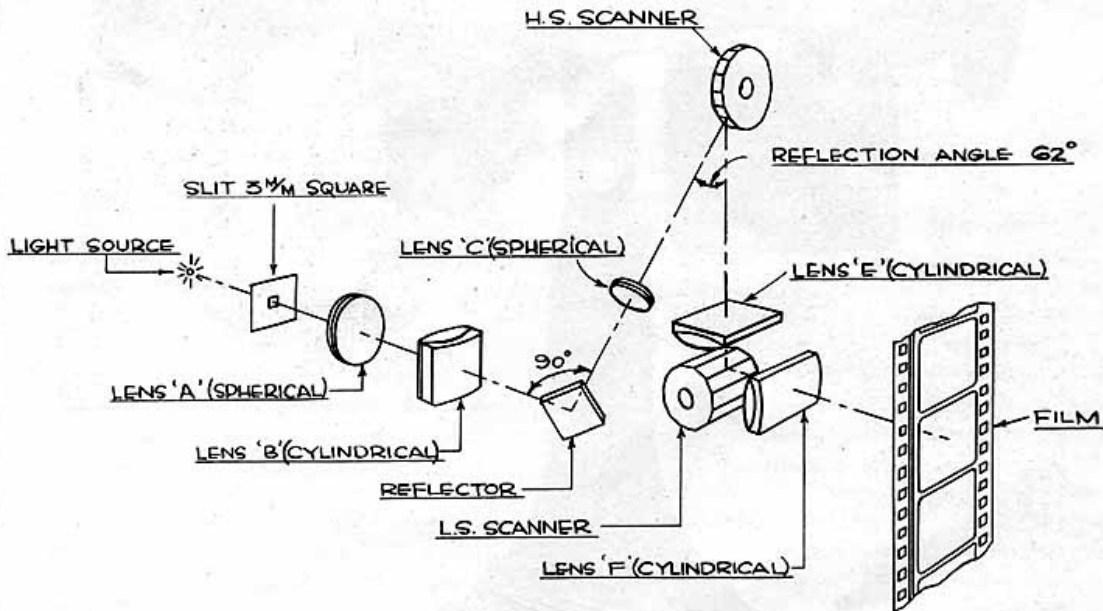

NOTE : ALL LENSES ARE ACHROMATIC
 SCHEMATIC DIAGRAM OF THE OPTICAL
 SYSTEM USED IN THE SCOPHONY FILM
 TRANSMITTER

1938

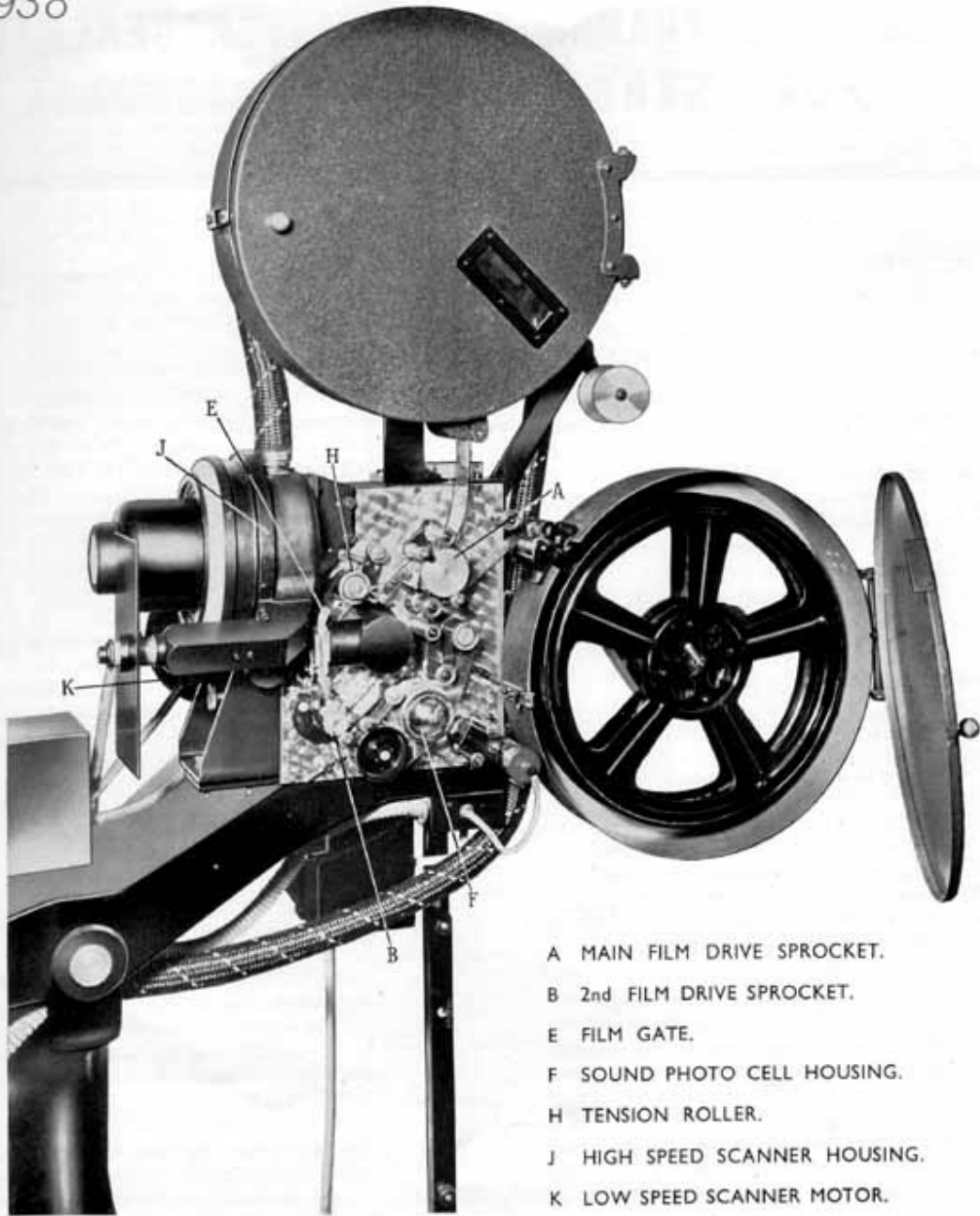

- A MAIN FILM DRIVE SPROCKET.
- B 2nd FILM DRIVE SPROCKET.
- E FILM GATE.
- F SOUND PHOTO CELL HOUSING.
- H TENSION ROLLER.
- J HIGH SPEED SCANNER HOUSING.
- K LOW SPEED SCANNER MOTOR.

SCOPHONY UNIVERSAL FILM TRANSMITTER
CLOSE UP VIEW OF SCANNING HEAD AND FILM DRIVE

SCOPHONY

TELEVISION TRANSMITTER MASTER GENERATOR FOR SYNCHRONISING SIGNALS

THE PROBLEM

High definition television systems depend for satisfactory synchronisation on the accurate timing of the transmitted synchronising signals. These are usually derived from some form of master generator working at line frequency or double line frequency. The framing pulses are derived from this frequency by subdivision. It is important that the frame pulses should be synchronised to the supply mains and show only negligible phase variations with the mains frequency. This is essential for film transmission and is an advantage generally, because smoothing requirements are not so stringent (stationary hum bands are less objectionable than moving ones).

FORMER METHODS AND THEIR SHORTCOMINGS

Two methods have been used heretofore to generate the master frequency. In the first a free oscillator is used automatically tuned so that the frame pulse, obtained by subdivision, remains in constant phase relation with the supply mains. In the second, use is made of an apertured disc with a lamp and photo cell, the disc being driven by a synchronous motor from the supply mains.

The electronic generator has been used in two distinct forms. In one the time constant of the automatic tuning system is small (of the order of 0.2 sec.). This results in very fast and erratic phase modulation of the oscillator output. Fig. 1 shows an oscillogram of the output of such a generator. The two lines are traces of successive synchronising pulses made on moving film. The lateral displacement at any moment indicates the change of phase relative to a standard signal. Measurements of this record show that the maximum curvature of the trace corresponds to a frequency variation of some hundreds of cycles per second per second.

No. 2 is an oscillogram of a generator of the same type on an enlarged time scale. Every horizontal black line corresponds to 1/50th of a second.

There are several reasons for this frequency variation, one is that the automatic tuning system corrects the frequency of the master generator only if the phase difference relative to the mains frequency is of a certain minimum value. The correction is not like a positive drive, but acts only after a considerable displacement has taken place. In general the correction takes place *quickly* and in the form of overcorrection. The result is a swinging about a mean position.

In the second form a large time constant coupling is used. This reduces the frequency variation to about 10 cycles per second/second at the line frequency as shown in Fig. 3, but the phase drift at frame frequency cannot be tolerated (see Fig. 4 which is a record of the frame pulses).

In this case, the frequency of the swinging about the mean position is reduced, but the amount of variation is increased.

The mechanical generator using the simple apertured disc suffers from mechanical irregularities in manufacture. For instance a disc having 405 holes designed to rotate at 1500 r.p.m. requires the angular spacing of the holes to be 6.4 seconds of arc for one element accuracy. Inaccurate placing of the holes would mean that the lines of the picture are displaced in time.

In addition to this irregular error, regular errors can be present if the holes are not at the same radius from the centre of the disc and/or the disc runs eccentrically on its shaft. When these errors are present the produced signal will not be a single frequency but a small band of frequencies (irregular placing) which are phase-modulated with a frequency corresponding to the number of revolutions of the disc per second.

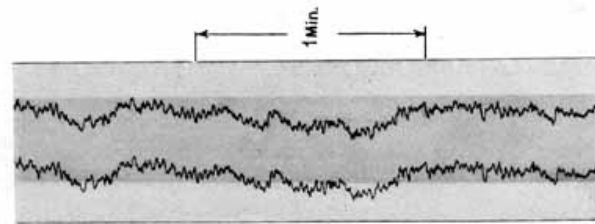

Fig. 1
Electronic gen with
small time constant
coupling.

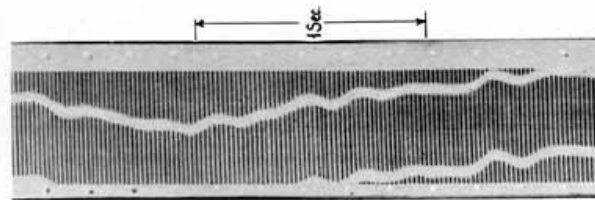

Fig. 2
The same as Fig. 1
on an enlarged time
scale.

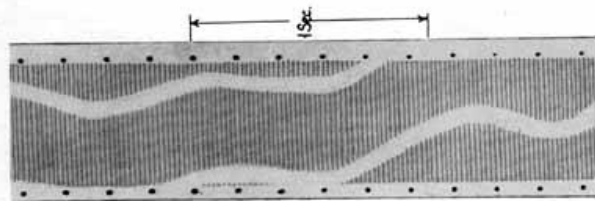

Fig. 3
Electronic gen. with
large time constant
coupling.

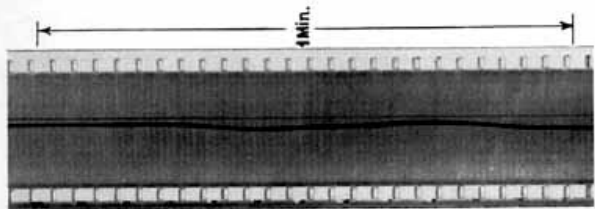

Fig. 4
Frame impulse drift
of 3 against the
mains

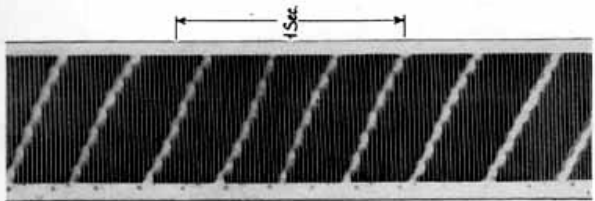

Fig. 5
Apertured disc
master generator

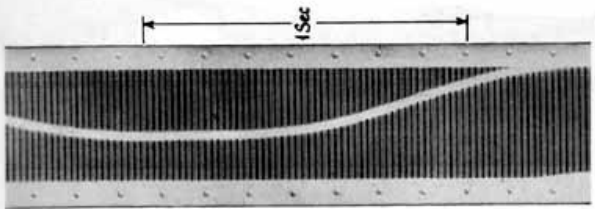
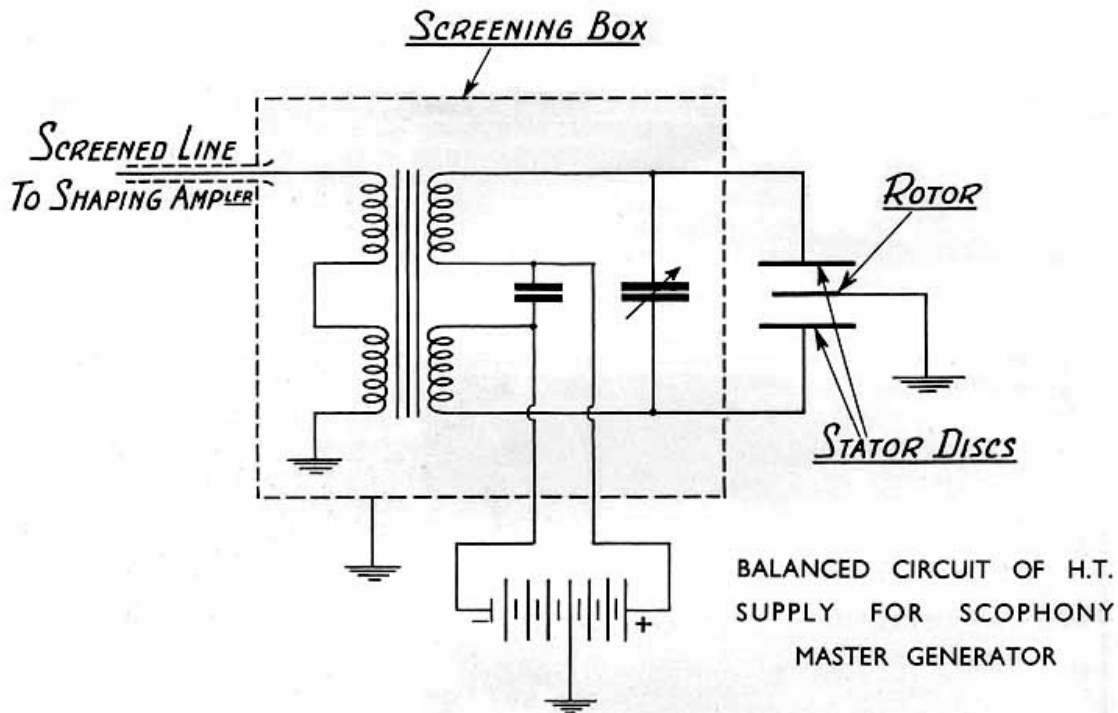

Fig. 6
Scophony
Master gen.

In taking oscillograms 1 and 4 the oscillograph time base was synchronised to the mains, in the other cases, to a magnetostriction oscillator.

OSCILLOGRAMS OF SIGNALS OBTAINED FROM MASTER GENERATORS OF DIFFERENT TYPES



Oscillogram No. 5 is a typical example from a generator constructed on these principles; the lines are not sharp but blurred because of the irregular placing of the holes and they show regular steps due to the eccentric error.

Any attempt to compensate variations electrically by means of sharply tuned circuits fails as the mains frequency drift is too great.

THE SCOPHONY SOLUTION

The Scophony master generator consists of a disc having teeth on its periphery which rotates between two stator rings also having teeth cut in them. Use is made of the change in capacity between the stators when the rotor revolves. The teeth are cut on an optical dividing head to an accuracy of 6 seconds. Owing to the large number of teeth uniformly placed around the periphery of the disc, all simultaneously contributing to the

output, all angular inaccuracies in the teeth cancel out. Likewise eccentricity in the mounting of stators or rotor cannot have any effect on the regularity of the signal. Skewed mounting of stators or rotor cannot have any effect on the signal due to the completely balanced electrical system used.

To compare the maximum frequency variation of the Scophony generator with that of the other generators, tests were made using as a standard a magnetostriction oscillator having a stability of one part in several hundred thousand. Measurements of these records show the maximum variation recorded for the Scophony generator to be less than 2 cycles per second at 10,125 cycles/second (see Fig. 6). The variation is of the order of the variation of the mains frequency against absolute time represented by the magnetostriction oscillator. The maximum phase drift of the frame pulse derived from it is of the order of 10^{-4} seconds or .5%.



SCOPHONY MASTER GENERATOR
(CLOSE UP VIEW)

The use of a synchronising signal at the transmitter with a small rate of change is advantageous in the case of cathode ray receivers and is essential with mechanical receivers.

If the rate of change of the line frequency is small the power required to synchronise the time-base at the receiver is also small, resulting in better synchronisation.

Using interlacing, it is important that the horizontal and vertical scanning frequencies should be in a definite relation to each other, otherwise faulty interlacing will result.

In cathode ray tube receivers the frame impulse

gives only the timing of the start of the frame time base, during the scanning stroke the time base is free. If during this time the line frequency changes to an extent which would demand a different frame scanning speed for correct interlacing, an irregular vertical spacing of the lines will result.

The Scophony master generator can be made for any practical number of lines and can be added to any existing synchronising equipment to produce the necessary coupling to the electric supply mains. Page 23 illustrates a complete synchronising equipment to provide all the synchronising impulses for the correct working of cathode ray tube or mechanical transmitters and receivers.

1938

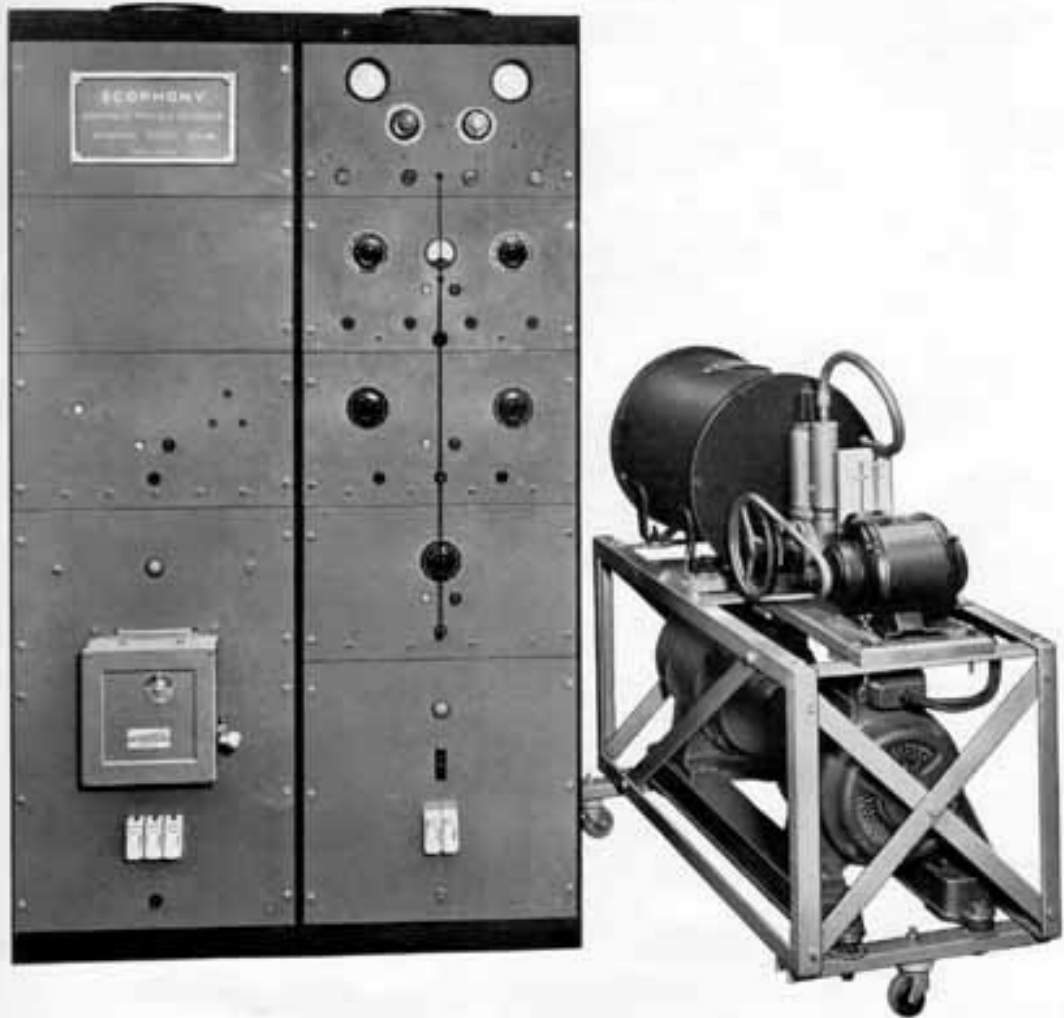

SCOPHONY SYNCHRONISING EQUIPMENT

1938



SCOPHONY UNIVERSAL FILM TRANSMITTER
AND C.R. MONITOR RECEIVER
COMPLETE WITH VISION, SOUND
AND SYNCHRONISING AMPLIFIERS

End of document